

LUX ELEMENTS®-ADD-EH Z...

Mounting and operating instructions



LUX ELEMENTS®-ADD-EH ZA
electronic temperature controller without timer
for flush mounting (12 A, 230 V AC)
... see page 2

ZA



LUX ELEMENTS®-ADD-EH ZB
electronic temperature controller with timer
for flush mounting (12 A, 230 V AC)
... see page 4

ZB



LUX ELEMENTS®-ADD-EH ZD
electronic temperature controller with timer,
with LCD display, for flush mounting (16 A, 230 V AC)
... see page 7

ZD



LUX ELEMENTS®-ADD-EH ZC
electronic temperature controller
for mounting in distribution cabinet (6 A, 230 V AC)
... see page 9

ZC

IMPORTANT NOTE

CAUTION: · Work on the 230 V mains supply may only be carried out by a qualified electrician.
· The national (Germany: VDE) and local electricity supply company safety regulations must be complied with when connecting the appliance.



CAUTION: · In the event of a fault, mains voltage may be present on the sensor cable. Connecting cables must be straight and the insulation stripped by about 6 mm.
· The sensor cable must be laid in a separate protective pipe and must not be laid together with cables that conduct mains voltage.

CAUTION: · Type of protection IP 30 = no protection against penetrating water!
· The controller must be protected from moisture and water vapour (relative air moisture < 60 %).

Please refer to our data sheets. Valid data sheets and test certificates can be downloaded from www.luxelements.com

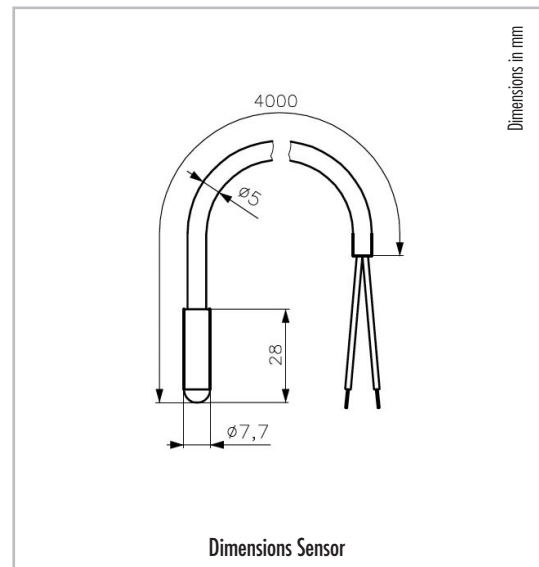
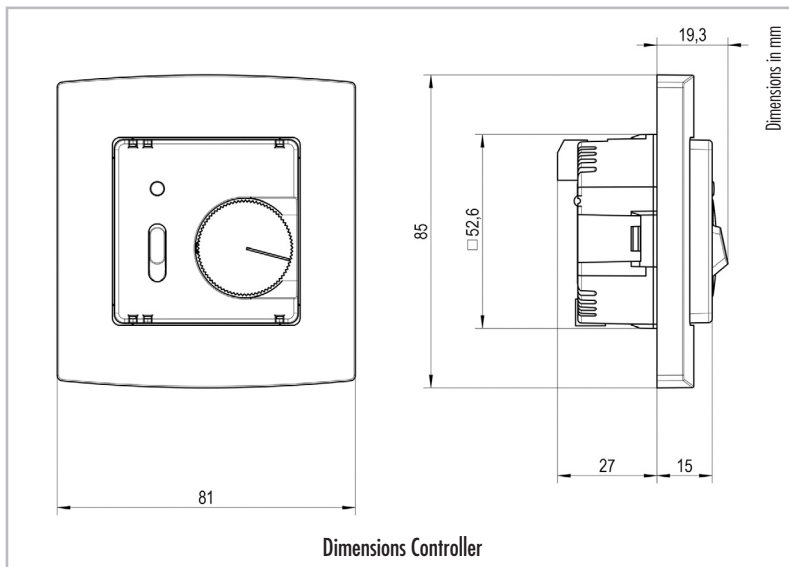

TECHNICAL DATA

- | | | | |
|-------------------------|--|-------------------------------|--|
| ■ Operating range: | 230 V/50 Hz | ■ Sensor breakdown detection: | heating is turned off, red LED flashes |
| ■ Control range: | 10 ... 50 °C | ■ Indicators: | red LED for 'heating' |
| ■ Switching difference: | ~1,5 K | ■ Terminal screws: | Supply: 0,75 – 4,0 mm ² ,
sensor: 0,08 – 1,5 mm ² |
| ■ Power consumption: | 0,8 W (6,5 VA) | ■ Mounting: | in an UP box (Ø 55 mm) |
| ■ Temperature decrease: | approx. 5K (fixed); (connection L1 → ☹) | ■ Degree of protection: | IP 30 |
| ■ Switching contact: | Relay / normally open contact,
mode of action type 1.C | ■ Protection class: | II (after corresponding installation) |
| ■ Switching capability: | 10 (1,5) A / 230 VAC | ■ Ambient temperature: | 0 ... 35 °C |
| ■ Switching power: | 2300 W | ■ Storage temperature: | -20 ... +70 °C |
| ■ External sensor: | 2k, NTC acc. to. DIN 44574
(double-insulated) in compliance with DIN EN 60730-2-1 | | |

Area of application / functional method

Application example for the electric bench heating: The control variable is the bench temperature. This is measured by means of the remote sensor at the heating mat level. The appliance comprises the control module for setting the desired temperature and a temperature sensor which measures the temperature and communicates the measured value to the control module.

Functioning

The controller measures the temperature by means of a remote sensor which is placed inside the building component. In case the temperature adjusted at the set value knob is underrun, the contact with the heating is closed down (scale * ... 6 corresponds to ca. 10 ... 50 °C temperature). The active state of the heating system is indicated by the red lamp. The heating system can be deactivated with the switch. When connecting the phase to the terminal Ⓢ, the controller decreases the adjusted set value by approx. 5K.

Opening the controller

- Lift out the thumb wheel (1) carefully using a screw driver
- Unscrew the fixing screw (2)
- Remove controller cover (3)
- Take off switch frame (4)

Installation controller

Caution, switch off mains voltage at all poles before installation!

- Electric connection according to 'schematic diagram' with screw terminals
- Cross section of solid wire is load-dependant 1,5 ... 2,5 mm²
- No protective conductor
- Install controller and support ring (5) in the flush-mounted box on the wall by screws

Installation sensor

- Between heating loops without contact
- Sensor lead inside protective tube
- Parallel laying with power cord prohibited
- Extension up to 50 m with 0.5 mm² (flexible conductors with cable end sleeve)
- **In the event of a fault or false connection, mains voltage may be present on the sensor.** Therefore, the sensor is double insulated according to EN 60730-2-1. Extension is only permitted, using double insulation according to EN 60730-2-1.

Close down device

Close down of the device is effected in reverse order to opening.

Limitation of the setting range

- Remove pin (6)
- Turn red pin (7) for maximum temperature and blue pin for minimum temperature (8)
- For fixation of the limits, plug-in the pin (6)

Connection of night decrease Ⓢ

If connected to terminal Ⓢ, night decrease is activated. This can be effected e.g. by a timer or a watch regulator. **(Caution! Two supplies) – if working at connector, the night decrease is to be turned off as well.**

Accessories

The controller is completely supplied with 4 m sensor sleeve (order designation HF-8/4-K2).

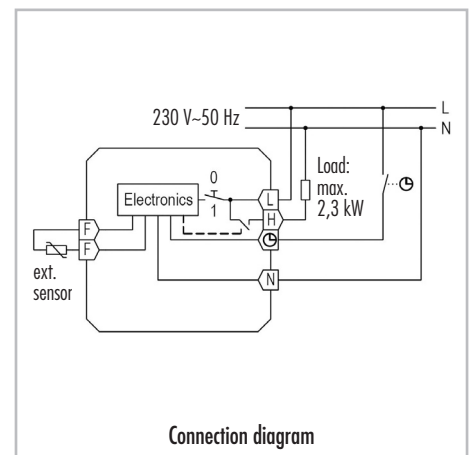
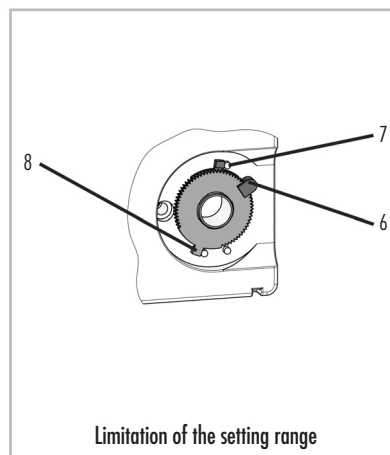
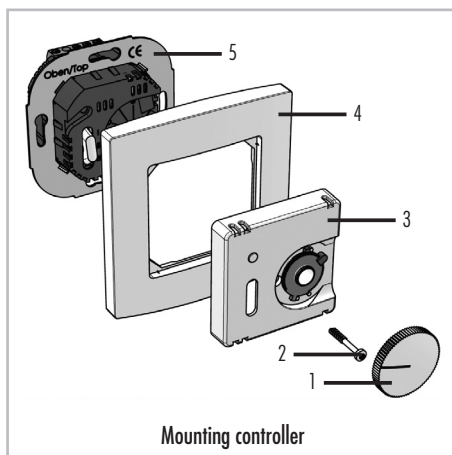

Explanation of symbols

- | | |
|--------------------|-----------------------------------|
| Ⓢ Control ON (red) | H Heating connection |
| ○ Control OFF | Ⓢ Connection Temperature decrease |
| ● Heating ON (red) | L Phase connection |
| | N Neutral conductor connection |
| | F Sensor connection |

Sensor characteristic curve

Temperature [°C]	Resistance [k-Ohm]
10	3,66
20	2,43
25	2,00
30	1,65
40	1,15
50	0,82

Please refer to our data sheets. Valid data sheets and test certificates can be downloaded from www.luxelements.com.

IMPORTANT NOTE

- CAUTION:** · Work on the 230 V mains supply may only be carried out by a qualified electrician.
· The national (Germany: VDE) and local electricity supply company safety regulations must be complied with when connecting the appliance.
- CAUTION:** · In the event of a fault, mains voltage may be present on the sensor cable (see fig. 1). Connecting cables must be straight and the insulation stripped by about 6 mm.
· The sensor cable must be laid in a separate protective pipe and must not be laid together with cables that conduct mains voltage.
- CAUTION:** · Type of protection IP 30 = no protection against penetrating water!
· The controller must be protected from moisture and water vapour (relative air moisture < 60 %).



Please refer to our data sheets. Valid data sheets and test certificates can be downloaded from www.luxelements.com

1 Temperature controller connection

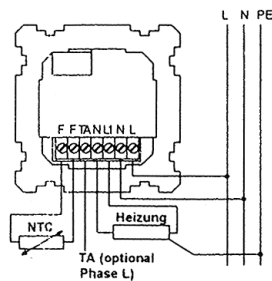

2 Overview of appliance (operating controls)

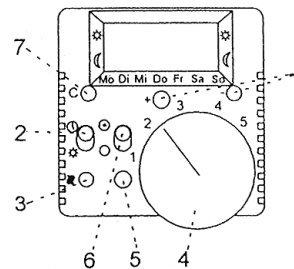

3 Display indications

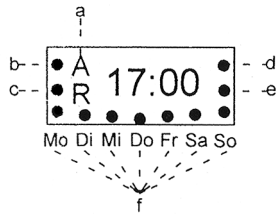

- a. Day groups: A = weekdays, R = rest days (Sat & Sun)
- b. 1st heating period
- c. 1st temperature reduction period
- d. 2nd heating period
- e. 2nd temperature reduction period
- f. Days of the week: Mon to Sun (from left to right)

Key to figure 2

- 1. '+' and '-' buttons = function: changing the setting variables
- 2. Sliding switch ('party switch') = function: changing between timer programme and continuous operation
- 3. LED display = function: heating ON / OFF
- 4. Thumbwheel = function: temperature setting
- 5. RESET button = function: deleting time and day; heating and temperature reduction periods remain unchanged
- 6. Sliding switch = function: heating ON / OFF
- 5. 'C' button = function: program sequence

NOTE: The factory setting is restored by pressing buttons 'C' (item 7), '+' and '-' (item 1) simultaneously.

TECHNICAL DATA

- Mains voltage: 230 V ~ ± 10 %, 50 Hz
- Switching current for 6025: approx. 12 A $\varphi = 1$, switching power 3,6 KW
- Switching temperature difference: 0,7 K
- Temperature sensor: NTC (according to DIN 44574), length 4 m
- Ambient temperature: -10 to +40 °C
- Connecting cables: max. 2,5 mm²
- Sensor characteristic curve:

Temperature [°C]	Resistance [k-Ohm]
10	3,66
20	2,43
30	1,66
40	1,15
50	0,82

Area of application / functional method

The electronic temperature controller with timer serves for the control of temperature. The appliance comprises the control module for setting the desired temperature and a temperature sensor, which measures the temperature and communicates the measured value to the control module.

Application example for the electric bench heating: the control variable is the bench temperature. This is measured by means of the remote sensor at the heating mat level.

The integrated digital clock enables switching from heating to reduced temperature twice per day, i.e. up to two different heating and reduced temperature phases can be specified differently for weekdays (e.g. Mon to Fri) and rest days (e.g. Sat, Sun). The assignment to weekdays/rest days can be changed.

The sliding switch 'On / Off' (fig. 2, item 6) isolates one pole of the heating from the mains supply and switches off the appliance completely except for the clock.

The sliding switch 'Timer programme/continuous operation' (fig. 2, item 2) enables switching from timer-controlled heating regulation to heating control without timer (e.g. continuous operation for a party).

Mounting

CAUTION! Switch off the mains voltage!

Mounting the temperature controller: both controllers are installed in commercially available flush-mounted boxes x 55 mm (in accordance with DIN 49073, part 1). If additional intermediate terminals are used, we recommend the use of a deeper switch boxes.

- Lift out the thumbwheel carefully using a screwdriver
- After unscrewing the fixing screw, remove the controller cover
- Refer to fig. 1 when connecting
- **CAUTION!** Position the support ring on the wall and mount the controller in the box using the self-tapping flush-mounted box screw
- Then place the frame and the cover on the flush-mounted insert and screw it tight
- Finally push the thumbwheel (with the groove positioned correctly) onto the appliance

Limiting the temperature range

The temperature setting range of the controller can be mechanically limited by reducing the angle of rotation of the thumbwheel. To do this, proceed as follows:

- Lever up the thumbwheel (see fig. 2, item 3) carefully using a screwdriver
- Pull out the stop pin (of the range limiter on the appliance cover) with the aid of a pair of long-nosed pliers
- Turn the small gear wheel in order to limit the movement of the thumbwheel
- To fix the thumbwheel again, proceed in the reverse order
- The mains voltage need not be switched off to limit the temperature range

Commissioning

The controller is factory-programmed as follows:

- 6:00 to 21:59: heating period, temperature selection via thumbwheel
- 22:00 to 5:59: reduced temperature of 15 °C
- Weekdays (Mon to Fri)
- Rest days (Sat, Sun)

Commissioning/setting the time

If you wish to use the factory-set values, proceed as follows to commission the appliance:

- Press button 'C' and set the time using the buttons '+' and '-'.
- The time will be shown on the display.
- Press button 'C' again and set the day of the week using the buttons '+' and '-'.
- The day of the week will be displayed (see fig. 3, item f)

The controller switches automatically to operating mode after 3 minutes. The values entered previously (time and day of the week) will thereby be adopted. Commissioning is now complete and the appliance is operating.

NOTE: To adapt the controller to your individual requirements, please proceed as described in the chapter 'Programming'.

Programming

If you wish to use other values (see also chapter 'Commissioning'), the controllers are programmed in the following order (factory settings in brackets):

- Reduced temperature (15 °C)

for weekdays:

- Start of 1st heating period (06:00)
- Start of 1st reduced temperature period (22:00)
- Start of 2nd heating period (00:00)
- Start of 2nd reduced temperature period (00:00)

for rest days:

- Start of 1st heating period (06:00)
- Start of 1st reduced temperature period (22:00)
- Start of 2nd heating period (00:00)
- Start of 2nd reduced temperature period (00:00)

The following steps are necessary in order to program each individual category:

- Press button 'C' and set the new value using the buttons '+' and '-'.
- The values/indications will be updated on the display.
- Press button 'C' to end programming

NOTE: Programming can be ended at any time by pressing button 'C'. The controller will display the 'current' time again automatically after three minutes and will continue to work with the values entered.

Programming example:

In the following example, the reduced temperature and the first heating and first reduced temperature period for the weekdays are to be changed; the settings for the rest days should remain unchanged.

Proceed as follows to programme:

- Press button 'C'
- the current time will be displayed
- Press button 'C' again
- the current day of the week will be displayed
- Press button 'C' again
- Set the reduced temperature using '+' and '-'
- the new reduced temperature, e.g. 15 °C, is displayed
- Press button 'C' again
- the symbol A and the weekdays are displayed
- Set the first heating period using '+' and '-'
- the start of the new first heating period, e.g. 7:00, is displayed
- Press button 'C' again
- the symbol A and the weekdays are displayed
- Set the first reduced temperature period using '+' and '-'
- the start of the new first reduced temperature period, e.g. 22:00, is displayed
- Press button 'C' again
- Do not make any further entries
- The controller works with the new values after 3 minutes

Restoring the factory setting:

The simplest way to restore the above-mentioned factory setting is as follows:

- Press the buttons 'C', '+' and '-' simultaneously (see fig. 2)
- After that please update the time and day of the week (see chapter 'Commissioning').

Definition of work and rest days

The factory-defined weekdays (Mon to Fri) and rest days (Sat, Sun) can be changed as follows:

- Press the buttons '+' and '-' simultaneously
- Then press button 'C'
- the symbols for all days of the week appear on the display
- the symbol 'A' and 'Mon' flash
- Press button '+' to turn Mon into a rest day
- the symbol 'A' disappears and the symbol 'R' appears
- the symbol 'Mon' flashes

- Press button 'C' to activate the next day (Tue) and proceed in the same way
- Press buttons '+' and '-' simultaneously to return to normal controller mode

You can switch between 'R = Rest days' and 'A = Workdays' using buttons '+' and '-'.

Confirm each change by pressing button 'C'.

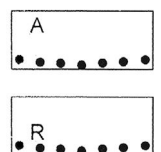

Operation

Continuous operation

If you do not wish your heating to be controlled by the timer, switch the left sliding switch (fig. 2, item 2) downwards to 'Continuous operation' (sun symbol). (The clock programming is not affected by this. After switching back to the 'Timer programme' position, the controller continues to work in accordance with the defined heating period pattern).

Switching off the heating

If you wish to specifically turn off your heating, please switch the right sliding switch (fig. 2, item 2) downwards (circle symbol).

Switching on the heating

If you wish to specifically turn on your heating, please switch the right sliding switch (fig. 2, item 2) upwards (circle/dot symbol).

NOTE: the LED display lights up only when heating is required.

Power cut

In the event of a power cut or an open or short circuit of the sensor cable, the heating is switched off.

The display (fig. 2) starts to flash. The time will be displayed for approx. two more days. The programmed values are retained, however. Reset the time if necessary (see chapter 'Commissioning').

CAUTION! In the event of a fault, mains voltage may be present on the sensor cable.

Troubleshooting

Diagnosis	Possible cause/remedy
Heating doesn't work	<ul style="list-style-type: none"> - Switch on/check the mains voltage - Check the heating - Check the sensor cable - Check the set temperature - Check the reduced temperature
Display is blank	<ul style="list-style-type: none"> - Switch on/check the mains voltage - Check the appliance
Controller switches too early/late to heating/reduced temperature period	<ul style="list-style-type: none"> - Check work and rest day settings - Press RESET, then carry out settings again
LED flashes	<ul style="list-style-type: none"> - Sensor is not connected or is defective

Please refer to our data sheets. Valid data sheets and test certificates can be downloaded from www.luxelements.com

IMPORTANT NOTE

- CAUTION:** - Work on the 230 V mains supply may only be carried out by a qualified electrician.
- The national (Germany: VDE) and local electricity supply company safety regulations must be complied with when connecting the appliance.
- CAUTION:** - In the event of a fault, mains voltage may be present on the sensor cable. Connecting cables must be straight and the insulation stripped by about 6 mm.
- The sensor cable must be laid in a separate protective pipe and must not be laid together with cables that conduct mains voltage.
- CAUTION:** - Type of protection IP 30 = no protection against penetrating water!
- The controller must be protected from moisture and water vapour (relative air moisture < 60 %).



Please refer to our data sheets. Valid data sheets and test certificates can be downloaded from www.luxelements.com

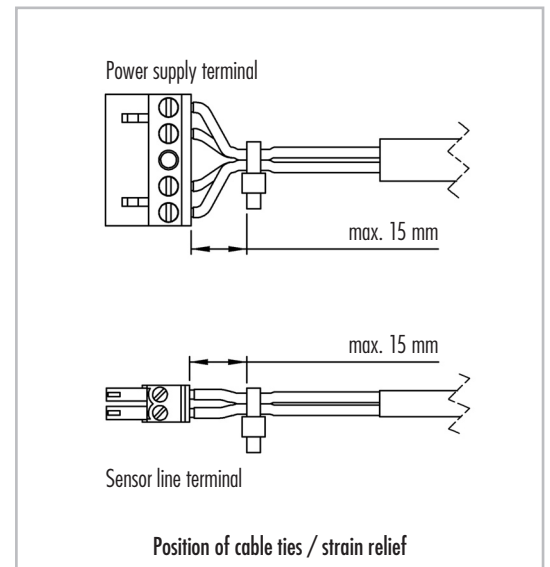
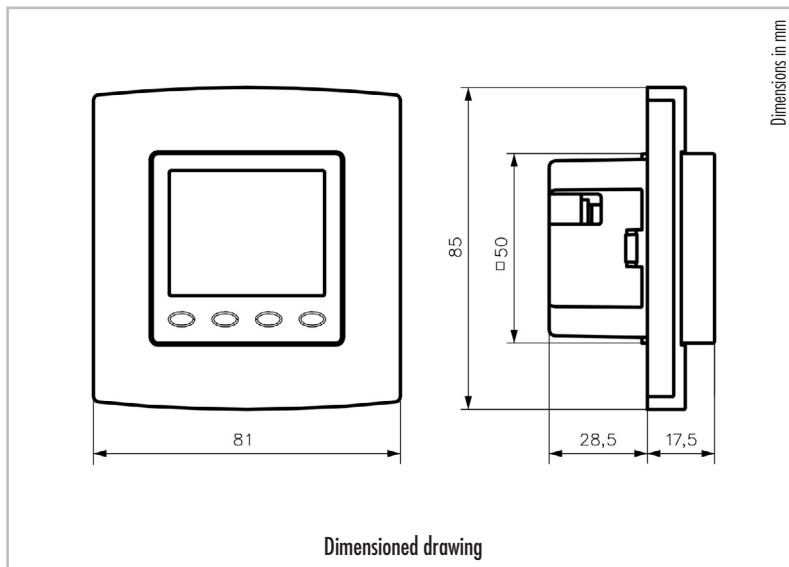

TECHNICAL DATA

- | | | | |
|-------------------------|--|----------------------------|---|
| ■ Operating voltage: | 230 V~, 50 Hz | ■ Display: | graphic display, backlit |
| ■ Sensor: | NTC – internal
NTC – externally connectable type | ■ Degree of protection: | IP 30 |
| ■ Switching contact: | relay / make contact | ■ Protection class: | II, after corresponding installation (see drawing) |
| ■ Switching capacity: | 10(2) A / 230 V~ | ■ Power reserve: | approx. 5 days |
| ■ Setting range: | 5 ... 30 °C (control of room temperatures)
10 ... 42 °C (control of floor temperature) | ■ Admissible air moisture: | max. 95 %, non condensing |
| ■ Switching difference: | < 1 K | ■ Storage temperature: | - 20 ... + 70 °C |
| ■ Temperature decrease: | decrease temperature adjustable
control of room temperatures: 5 ... 29 °C
control of floor temperatures: 10 ... 41 °C
(factory setting 17 °C) | ■ Ambient temperature: | 0 ... 35 °C |
| | | ■ Housing colour: | pure white or pearly white or traffic white |
| | | ■ Housing material: | PC, PMMA, ABS |
| | | ■ Installation / mounting: | in an UP box; suited for integration into all currently available flush mounted switch frame installation systems |

Application / functional description / emergency operation

The controller described in these instructions is provided for flush installation and has been specially devised for the time-dependent control of the temperatures in individual rooms or of the temperatures produced by electric or warm-water heating systems (systems with normally closed valve actuators). The device can be used as floor or as room temperature controller with additional floor temperature controller function. Operation in emergency mode is triggered if the internal or external sensor is defective. The same applies if no sensor has been connected when using the device as room temperature controller with additional floor monitoring function and also when using it as floor temperature controller. An error message appears on the display and an indicator lamp starts blinking red to indicate this condition. During operation in emergency mode a fixed 30 % duty cycle is being maintained to prevent the related room from cooling down thoroughly and protect it against frost damage. The activation time divides into a 3-minute ACTIVE and a 7-minute OFF time.

The device is equipped with 4 touch keys, all of which have been marked by the symbol . The functions allocated to them may vary in dependence on the operation requirements. The related function is being indicated on the display which exists above the corresponding keys. A special protective function helps prevent an inadvertent activation of the touch keys. This function is activated 20 seconds after any of the touch keys has last been activated. Actuating any of the touch keys deactivates this function again for 2 seconds.

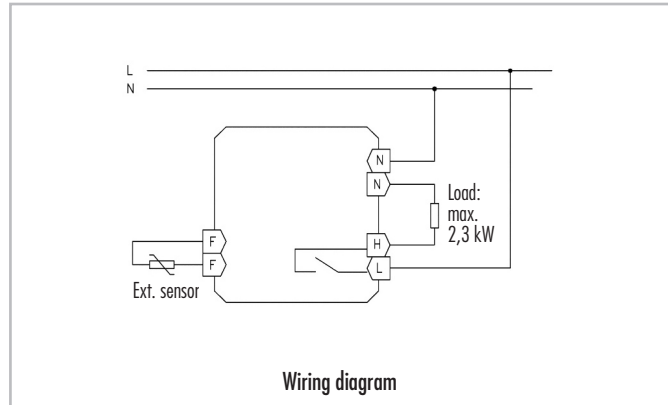

Wiring diagram

Instructions for use

Due to the wide range of operating and setting options for the controller, please refer to the detailed information in the operating instructions supplied with the controller or the operating instructions in the download area at www.luxelements.com

Please refer to our data sheets. Valid data sheets and test certificates can be downloaded from www.luxelements.com

IMPORTANT NOTE



CAUTION: Work on the 230 V mains supply may only be carried out by a qualified electrician. The national (Germany: VDE) and local electricity supply company safety regulations must be complied with when connecting the appliance.

CAUTION: In the event of a fault, mains voltage may be present on the sensor cable. Connecting cables must be straight and the insulation stripped by about 6 mm.

CAUTION: Type of protection IP 20 = no protection against penetrating water! The controller must be protected from moisture and water vapour (relative air moisture < 60 %).

Please refer to our data sheets. Valid data sheets and test certificates can be downloaded from www.luxelements.com

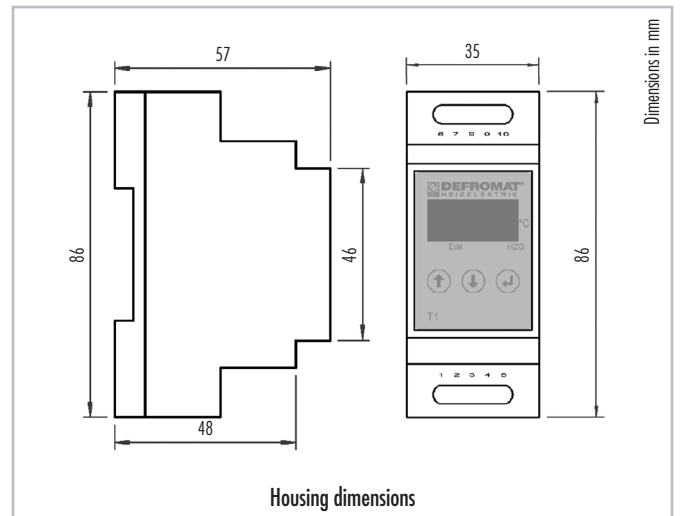

Dimensions in mm

Housing dimensions

General

The currently valid VDE and DIN regulations as well as the technical connection conditions (TAB) from the local electricity supply company must be observed during the installation of control units! Resistance measuring may only be carried out with a resistance tester. Insulation measurements may not be performed.

Fitting the measuring probe

The standard probes have a length of 3 m. Get in touch with us prior if you are laying the probe lines directly near power cables with frequent switching operations. Probe lines may be extended by a maximum of 500 m.

A semiconductor (NTC) is used as a temperature probe; it is cast integral inside a 5 x 50 mm protective sleeve and is connected using a flexible connecting lead 2 x 0.75 mm² with a PVC or silicon sheath. Temperature probes with silicone leads should be used for ambient temperature exceeding 70 °C. These are connected either directly on the control unit or via a terminal box.

The location in which the temperature probe is mounted depends on the type of heating and the task of the electric heater. The rule that generally applies is that the probe should be mounted in the place that is most suitable for acquiring the reference temperature (system temperature). For example, if the bench heating is to provide temperature equalisation for the surface, the temperature probe should be installed in lines near the surface. In the case of pipe accompanying heaters using a heating loop or between the heating circuits, these are offset by about 90 °C with a simple parallel layout. The temperature probe is situated directly on the tube underneath the insulation.

If limitation transfer elements are used for pipe accompanying heaters, then the corresponding temperature probe is fitted in parallel about 1 m from the heating line.

Fitting the measuring probe

All the measurements must always be taken while the probe lines are disconnected.

Test values on the temperature probe

The temperature probe that is used is characterised by a nonlinear, negative temperature resistance curve. Use the following table to check this:

Temperature [°C]	Resistance [k-Ohm]	Temperature [°C]	Resistance [k-Ohm]
-10	16,599	35	1,959
-5	12,699	40	1,598
0	9,795	45	1,311
5	7,617	50	1,081
10	5,970	60	0,746
15	4,713	70	0,526
20	3,747	80	0,377
25	3,000	90	0,275
30	2,417	100	0,204

Commissioning

The functionality of the entire control equipment and control system is tested after the control equipment and control system has been assembled and the installation of the control equipment and the measuring probe(s). The temperature is cooled down using cooling spray to below the required switching point or is carefully warmed up to the switch off point. That way, it is possible to control at what point the heating switches on using a clip-on ammeter or voltmeter. If you only want to test the function of the control equipment, the temperature can be simulated with a corresponding resistance between terminal 9 and 10.

The control equipment is designed in such a way that there is a potential-free relay output available (connection terminals 4 and 5). Switching is possible over the relay on the control equipment up to a heating capacity of 1kW approx.

The control equipment is equipped with a potential-free fault alarm output. This is especially intended for the mandatory monitoring of the temperature probe if sprinkler systems are being heated. This can also be used to monitor whether separate threshold values are exceeded or fall short.

The fault alarm output is closed when the control equipment is in an ON state between connections 6 and 7; in the event of a fault, the relay opens and the type of fault and the measured temperature are displayed alternately.

Fault

- Missing power supply
- Probe breakdown in temperature probe
- Probe short in temperature probe
- HI value exceeded
- LO value not attained

Display (alternating)

None	
F [∞]	---
F _U	---
HI	76
LO	3

Repeat the commissioning procedure annual when preparing system for operation.

Displays and settings

All the readings are shown on a three digit LED display

Standard display:

- 1 Temperature reading in °C
- 2 Edit (Decimal point on for first digit = Menu; off here)
- 3 Heating (Decimal point for last digit on = Heating on)

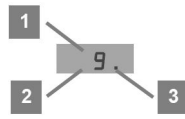

The following three keys are used for operation:

- 'ENTER' key to leave standard display and to change setpoints (Menu)
- 'UP' and 'DOWN' keys to call up individual required setpoints and actual values
- (Scroll forwards/backwards, adjust plus/minus)

The control equipment is delivered with a basic setting. The values for the temperature switching point equal +3 °C, and OFF is set for the HI and LO switching point.

These switching points can be altered for every specific system using the menu. Restoring the standard display is performed using the menu item ESC (confirm with ENTER) or occurs automatically after approximately 30 seconds.

The menu is addressed with ENTER; the required menu item is selected with UP and DOWN. To change the selected value, ENTER has to be pressed again; the value that is being changed appears then. UP and DOWN are used to change the value (the longer you press the button, the faster the values change). ENTER must be pressed to transfer the value that may have been changed.

Menu Item Switching Point

Display and temperature setting at which heating switches if value falls short.

Display	.5 P
Setting range	-30 °C ... 110 °C
Increments	1K
Basic setting	3 °C

Menu Item Alarm in case of temperature shortfall

A threshold value, at which the fault alarm output is opened in the case of a shortfall, can be set in this menu.

Display	.L D
Setting range	OFF, -30 °C ... SP-1K
Increments	1K
Basic setting	OFF

Menu Item Alarm in case of excessive temperature

A threshold value, at which the fault alarm output is opened in the event temperature is exceeded, can be set in this menu.

Display	.H I
Setting range	OFF, SP+1K ... 110 °C
Increments	1K
Basic position	OFF

Menu item Escape

This display is confirmed with ENTER, then you reach the standard display. This also occurs automatically without pressing the button after approximately 30 seconds.

Display	E.5 C
---------	-------

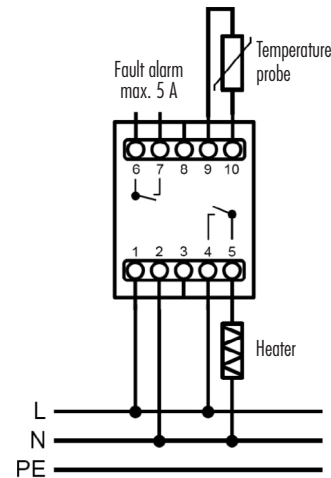

Connection diagram

TECHNICAL DATA

- Type: T1
- Voltage supply: 230V AC 50/60 Hz
- Power consumption: 5 VA (max.)
- Ambient temperature: -10 °C ... +50 °C
- Storage temperature: -40 °C ... +80 °C
- Measuring range: -40 °C ... +120 °C
- Output: Make contact relay
250 VAC / 150 VDC, 5A cos φ=1
- Fault alarm output: Make contact relay
250 VAC / 150 VDC, 5A cos φ=1
- Accuracy: +/- 1K (-30 °C ... +100 °C)
+/- 2K (< -30 °C; > +100 °C)
- Weight: about 160 g
- Connections Capacity: 0,5 ... 2,5 mm²
- Dimensions (approx.): W: 35 mm, H: 86 mm, D: 57 mm
- Class of protection: Protection class II
- Type of protection: IP 20
- Assembly: Snap on 35 mm DIN-Rail



Conformity in accordance with EMC Directive 2004/108/EEC as well as Low Voltage Directive 2006/95/EU.

Please refer to our data sheets. Valid data sheets and test certificates can be downloaded from www.luxelements.com.